

Brinsea

Octagon Pro-20

Precision Egg Incubation System

Users instructions

Contents

<u>Section</u>	<u>Subject</u>	<u>Page</u>
1	Introduction	2
2	Unpacking	3
3	Location and Installation	4
4	Storage of eggs	6
5	Temperature	6
6	Humidity and Ventilation	7
7	Humidity Management Module operation	7
8	Determining Correct Humidity	8
9	Egg Setting	9
10	Egg Turning	9
11	Hatching	9
12	Cleaning Up	10
13	Servicing	10
14	Troubleshooting	11
15	Specification	13
16	Certificate of Thermometer Accuracy	14

1.0 Introduction

These instructions detail the operation of your new Brinsea Octagon Pro-20 incubation system which is designed to provide the most exacting control for the incubation of small quantities of eggs. Please read these instructions carefully before setting up your machine to achieve best possible results and keep these instructions safe for future reference. This document includes recommended procedures for successful hatching but incubation involves the control and manipulation of a large number of factors and in certain circumstances different procedures may be necessary. Your incubator is designed to allow the user to vary and control the incubation conditions to suit a wide range of species in different ambient conditions and the specific set-up for every situation is beyond the scope of these instructions.

These instructions cover the use of the incubator and associated controls including the Humidity Management Module. Additional equipment (temperature alarm or brooder module, for example) may be used in conjunction with your Octagon Pro-20 and in these cases separate operating instructions for these modules are supplied.

There is also a range of books available covering incubation techniques, for more information or to request a book list please don't hesitate to contact us.

Fig. 1 *Functional features of the Octagon Pro-20 incubator package.*

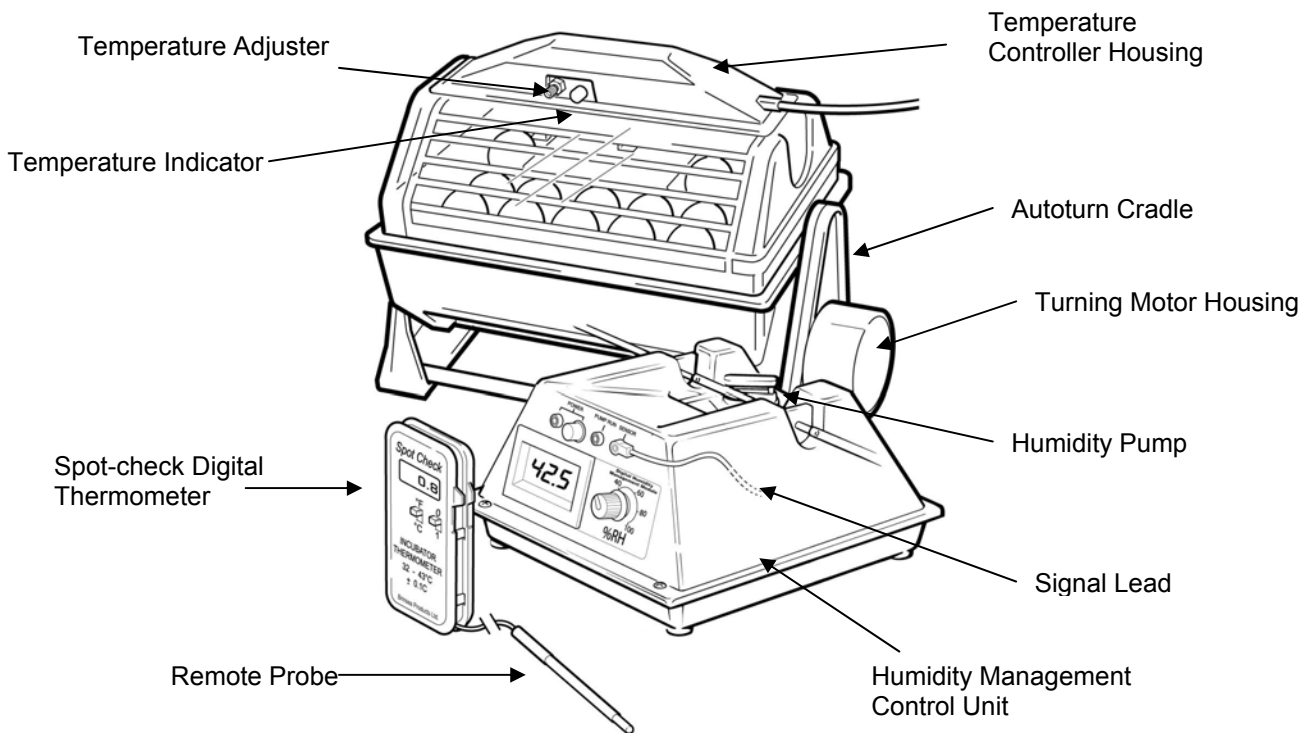

2.0 Unpacking

Your incubator has been supplied in protective packaging. Please remove all tape, strapping and packing from the incubator and parts. Retain the carton and packing materials to enable the unit to be repacked.

Your Octagon Pro-20 will include as standard:	<u>Quantity</u>	<u>Item</u>
Incubator:	1	Incubator (including removable lid)
	1	Egg tray (black)
	1	Set of six egg dividers & foam mat
	1	Spotcheck digital thermometer
	1	Guarantee Card
Autoturn Cradle	2	Black metal tubes
	1	Motorised cradle end
	1	Plain cradle end
	1	Set of four screws
Humidity Management Module	1	H22 humidity Management control unit (Free standing unit for mains electrical supply containing control and indication functions and pump.)
	1	Sensor unit Fits through the incubator wall. Contains the (removable) sensor, signal lead socket and mounting clip.
	1	Water tube (3m) Silicone rubber tube for interconnecting and for peristaltic pump replacement.
	1	Signal lead (1m) Flex with jack plugs for connecting between control unit and sensor unit.
	2	Evaporating pads (A4 size sheets)

(Note: A bulk water reservoir is not supplied. Any plastic or glass food container may be suitable.)

- 2.1 Please identify each part and check that they are all present and undamaged. If there are any parts damaged or missing please contact your retailer or Brinsea Products (at the address at the end of the document) Please take care not to discard the pack of heavy white evaporating pad paper. Note also that the black humidity sensor fits into a socket in the sensor unit and can be pulled to remove. **Take care not to lose or damage the sensor, replacements are expensive.**
- 2.2 Check also that the electrical supply matches the machine's requirements (marked on the technical label on the inside of the lid of the incubator and on the side of the autoturn cradle).
- 2.3 Complete and return your guarantee card to register for the free two year guarantee covering your incubator.
- 2.4 Go to www.Brinsea.co.uk and register as a free member of the Brinsea e-mail group to receive the latest news and information such as advance notice about new products, special offers, exclusive competitions and much more.

3.0 Location and Installation - Incubator

Your incubator will give best results in a room free from wide temperature variations and with generous ventilation – particularly if several incubators are running at the same time. Ensure that the room temperature cannot drop on a cold night. Ideally thermostatically control the room at between 20 and 25°C (68 and 77°F). Never allow the room temperature to drop below 15°C (59°F) and ensure that the incubator cannot be exposed to direct sunlight.

- 3.1 Assemble the autoturn cradle in accordance with the diagram below (Fig. 2) and place on a flat, level surface (table height is ideal). Place the incubator into the autoturn cradle as illustrated (Fig. 1). The cabinet is designed to locate onto the lugs at either end of the autoturn cradle. Take care to offer the incubator at the angle which matches that of the drive lug to avoid damage to the mechanism. Ensure full engagement in the slots in the ends of the incubator so that the incubator is level end to end.
- 3.2 If using without the autoturn cradle place the incubator upright on a flat level surface.

Fig. 2

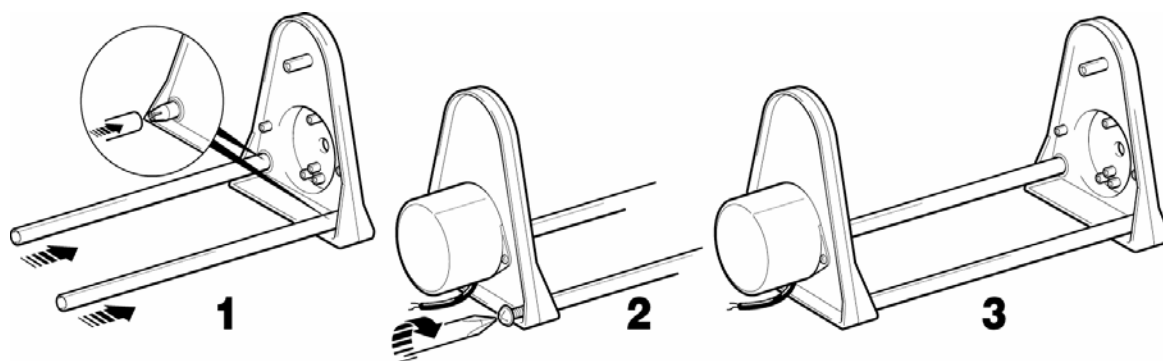

- 3.3 Uncoil a length of the Spotcheck digital thermometer sensor lead and push the end of the sensor through the small rubber grommet fitted into the black plate at the end of the incubator lid. The sensor should protrude at least 1.5”(40mm) into the incubator cabinet. Alternatively you can push the end of the sensor through one of the four ventilation holes in the yellow base of the incubator. The sensor should be placed in a representative position, near the top of the eggs but not touching the eggs. You can clip or tape the sensor to one of the dividers. Never insert the sensor lead through the sliding ventilation control on the top of the incubator, this would damage the circulating fan. Some small difference is to be expected between any two thermometers. A Spotcheck close to the eggs should be preferred, the other being regarded as a backup. The Spotcheck is fitted with a battery, replacements are available from Brinsea Products at the address at the end of these instructions. We recommend not leaving the thermometer permanently switched on to preserve battery life.
- 3.4 Separate instructions and specifications for the Spotcheck digital thermometer are included. Note that a certificate of accuracy for the particular thermometer supplied as part of this Pro-20 is included at the end of these instructions. The Spotcheck has a range of 32 – 43°C (90-110°F) and so will not give a reading until this range is attained (an “L” for Low temperature will appear on the digital readout).
- 3.5 Slide the ventilation control to the centre of its range.
- 3.6 Plug incubator and cradle mains supply cables into suitable outlets ensuring that the cables are not pulled tight. The incubator fan will start and the red LED on the temperature control housing will illuminate continuously and the digital temperature display will show the air temperature. The cradle motor will start and the incubator will begin to turn. The turning is very slow – taking about half an hour to turn each way.
- 3.7 Allow the incubator to run for at least an hour to stabilise the temperature (red LED flashing) before making adjustments or setting eggs (see section 5.0 below).

3.8 Installation – Humidity Management Module

Connecting Up

Fig. 3

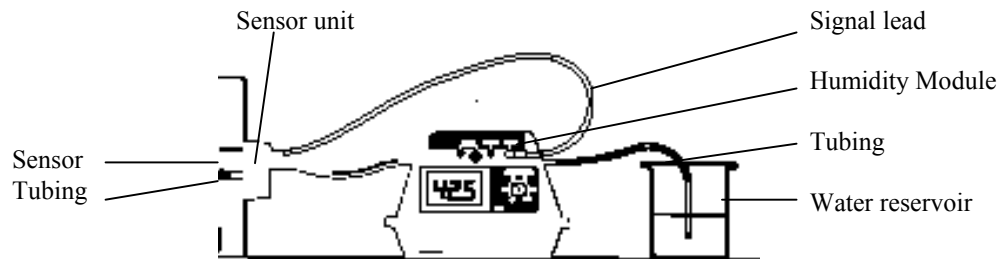

- 3.9 Push a 100mm (4 inch) length of the silicone tube to the nipple on the sensor unit adjacent to the black sensor (moistening the end of the tube helps). Ensure the sensor is firmly pushed into its socket in the sensor unit. If it should come out, ensure it is replaced the right way up with the side marked 'top', at the top. If inserted upside down, the sensor will give an incorrect negative reading. Push the whole sensor unit into the black mounting clip on the end of the clear incubator lid adjacent to the mains power cable, until it locates with a 'click'.
- 3.10 Cut a second length of silicone tube long enough to reach from the sensor unit to the Humidity Management Module and push one end onto the nipple on the outside of the sensor unit. The other end of this length is pushed onto the output (left side) of the Humidity Management Module (the label on the module shows the direction of water flow with an arrow).
- 3.11 The H22 Humidity Management Module is supplied with a length of silicone tube fitted around the pump rotor. This length will wear and need periodic replacement. It can also become flattened if left unused for some time because the inside walls of the tube will stick to each other around the rotor and prevent water passing through. This can happen from new if the unit has been stored for a time. Either replace this length of tube (see section 13) or remove it and roll it between finger and thumb to 'unstick' it.
- 3.12 Connect a last length of tube between the input to the pump (right side) and a water reservoir. A gallon of distilled water works well.
- 3.13 Plug one end of the sensor signal lead into the socket in the sensor unit and the other end into the socket in the Humidity Management Module.
- 3.14 Ensure that neither the tube nor signal lead can impede the rotation of the incubator.
- 3.15 Note that sensors for digital models of the H22 Humidity Management Module are black and not interchangeable with earlier white analogue models.

3.16 Fitting the evaporating pad (see Fig.4)

Cut a piece of evaporating pad 20cm x 6cm, scored and folded longways. The evaporating pad is suspended in a "V" arrangement, located in the slot on the underside of the fan guard. The pad is retained by two plastic clips which are pushed onto the two lugs on either end of the slot in the fan guard. The tube from the sensor unit is then laid in the centre of the "V".

Fig 4.

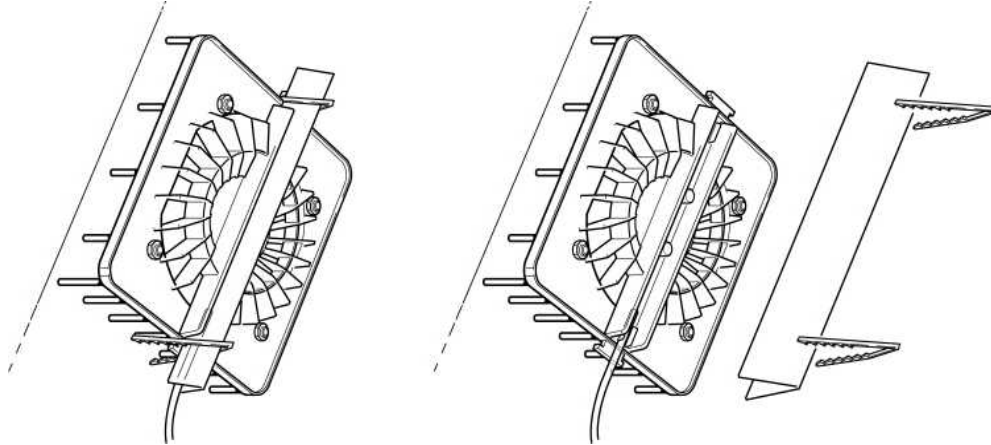

4.0 Storage of eggs

- 4.1 Store eggs in cool, damp conditions. Some species may be safely stored for up to 14 days before serious reductions in hatch rates are likely, parrot eggs store less well. Daily turning of stored eggs also helps maintain hatchability.
- 4.2 Discard cracked, mis-shaped and heavily soiled eggs (if possible). Only wash soiled eggs using a brand egg wash solution such as Brinsea Incubation Disinfectant Concentrate following the manufacturers instructions. It is essential to wash eggs in solution which is significantly warmer than the egg. Bear in mind that all solutions will remove the outer cuticle from the egg as well as the dirt and may leave the egg at greater risk from bacterial contamination in the future.

5.0 Temperature

Stable and correct temperature is essential for good results. Adjust with care.

Note: your incubator may not be set to the correct temperature from the factory and the following procedure must be followed before setting eggs.

- 5.1 As the incubator warms up and approaches its control setting the red LED will change from continuously on to flashing. Allow the incubator to stabilise for at least an hour before adjusting the temperature.
- 5.2 Rotate the red adjustment spindle with a small screwdriver – clockwise to increase temperature, anticlockwise to reduce it. 1°C (2°F) is about ¼ turn of the spindle.
- 5.3 When reducing temperature the red LED may go out while the incubator cools – this is normal.
- 5.4 Use the calibrated Spotcheck thermometer supplied to check temperature. Adjust temperature with care – small differences have large effects on hatching performance.

Recommended temperatures:

Hens	37.5°C	99.5°F
Pheasant	37.7°C	99.8°F
Quail	37.7°C	99.8°F
Ducks	37.5°C	99.5°F
Parrots:		
Amazons	37.2°C	99.0°F

Typical incubation period:

21 days
23-27 days
16-23 days
28 days
24-29 days

Macaws	37.2°C	99.0°F	26-28 days
Love birds	37.2°C	99.0°F	22-24 days
African Grey	37.2°C	99.0°F	28 days
Eclectus	37.2°C	99.0°F	28 days

- 5.5 Developing embryos are fairly tolerant of short term temperature drops and the user need not be concerned about cooling that occurs when inspecting eggs. Temperatures above ideal can quickly have a serious detrimental effect on hatch rates and must be avoided.
- 5.6 The Pro-20 may be used in conjunction with the Brinsea T20 temperature alarm system which gives audible and visual warning of mains failure, over temperature and under temperature. Contact your dealer or Brinsea Products for further details.

6.0 HUMIDITY AND VENTILATION

Short term variations in humidity are not important. The average humidity over the incubation period needs to be near optimum to achieve the ideal weight loss. High humidity for the day or two of hatching is also important. Beware chronic, excessive humidity.

- 6.1 The H22 Humidity Management Module, supplied as part of your Octagon Pro-20 gives complete and accurate control of humidity. The limits of its range of humidity achievable are dependant on the level of ventilation, ambient humidity levels and the levels of moisture being evaporated from the eggs (see section 14 for troubleshooting).

H22 FEATURES

- Continuous metering of relative humidity
- Proportional control easily set against scale
- Sensor unit with high accuracy bulk polymer sensor
- Pumped water flow - not level dependent

PRINCIPLE OF OPERATION

The sophisticated bulk polymer sensor provides a highly accurate, linear signal of the relative humidity level within the incubator back to the Humidity Module which then displays this level on the digital readout.

The control system operates a tiny in-built water pump which transfers exactly the amount of water required into the incubator to maintain the required relative humidity which is set by the user. The control system compensates for changes in relative humidity level and, within working limits, will maintain a constant relative humidity level.

7.0 Humidity Management Module - OPERATION

The module is supplied calibrated but may be returned to the address at the end of these instructions for re-calibration if necessary.

- 7.1 Fill a suitable container with distilled water and place the pump inlet tube into the container.
- 7.2 Press the power supply switch. Power indicator will light. Turn the humidity control knob anti-clockwise to minimum.
- 7.3 The meter will give a readout of humidity. At incubation temperature and particularly without eggs, this will usually be a fairly low figure. Allow 5 minutes for the reading to stabilise and adjust the humidity control knob to raise the humidity, the pump will run and the 'pump run' indicator will light. To achieve the desired relative humidity level allow 30minutes between adjustments and use the meter reading as your guide to turning the control knob up or down.

7.4 When the humidity level is stable the pump will cut in and out evenly, pumping small amounts of water to offset moisture losses as incubator air is passed out through ventilation holes.

7.5 Refer to section 8 on the ways of determining correct humidity settings for different species.

Generally accepted incubation RH levels for species groups:

During incubation	Waterfowl	45-55% RH
	Poultry	40-50% RH
	Parrots	35-45% RH
	Most Birds of Prey	40-45% RH
	(Thin shelled - Merlins, Kestrels, Owls	50%RH)
Hatching	All species	65% RH or more

For more specific information on particular species' requirements check the relevant literature.

8.0 Determining correct humidity setting – monitoring egg weight loss

Eggs lose moisture through their shells and the rate of evaporation depends on the humidity levels around the eggs. The range in recommended humidity level for any given species is because of individual differences in shell porosity between one egg and another – even if laid by the same bird.

There is a technique whereby water loss can be monitored during incubation, allowing the humidity level to be adjusted to keep water loss exactly right.

The need for eggs to lose a fixed amount of water during incubation corresponds to a loss in weight of around 13-16% depending on species. By weighing eggs periodically during incubation it is possible to monitor and, if necessary, correct humidity levels to achieve the correct weight loss.

Weigh the eggs on the day they are set in the incubator, take the average weight and plot this on a graph (see example below). The ideal weight loss line can be plotted by joining the point representing initial average weight with the ideal hatch weight (13-18% less depending on species) with the x-axis representing the incubation period (in days).

By measuring actual average weights every few days the actual weight loss can be plotted and compared to the ideal weight loss line and corrections can be made. For example if the actual weight loss was greater than ideal (see graph below) then the air has been too dry and humidity levels need to be increased to compensate.

Typical ideal weight losses for species groups:

Birds of Prey	17%
Poultry	13%
Parrots	16%
Waterfowl	14%

Egg weight loss chart

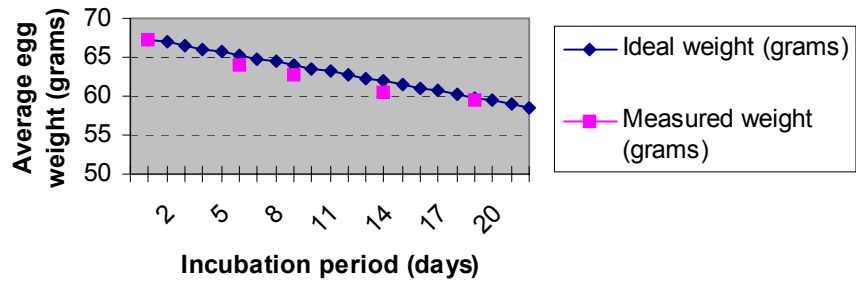

9.0 Egg Setting

- 9.1 The Octagon Pro-20 is designed to be as flexible as possible, accommodating eggs of different sizes up to duck eggs. Foam cushions isolate the eggs from potentially harmful vibration. Some experimentation may be necessary to maximise capacity.
- 9.2 Before setting eggs ensure that the incubator has been run for several hours and has stabilised at the correct temperature.
- 9.3 Set the eggs in rows between the plastic dividers. The dividers must be positioned such that the eggs rest on the foam mat on the egg tray base and are not pressured by the dividers. Eggs rolling through a few degrees between the dividers as the incubator turns are not in danger. Eggs may be set on end (or at an angle) provided the large end of the egg is upwards.
- 9.4 Once the eggs have been set the temperature must not be adjusted for 24 hours to allow the eggs to warm. Check the water level every 3 days or so and temperature daily. Candle the eggs after 1/3rd of the incubation period has elapsed to reject clear, infertile eggs (see section 14 for troubleshooting).

10.0 Egg Turning

Warning: **NEVER MANUALLY TURN THE INCUBATOR WHILE IT IS ON THE CRADLE**, this will damage the turning mechanism and invalidate the guarantee.

- 10.1 The autoturn cradle will continuously turn the incubator and eggs on an hourly cycle (through 90° and back) while plugged into the mains supply. Some small intermittent movement due to play in the gears is normal and does not cause harm. Lubrication of the plastic linkage with WD40 helps to ensure smooth, silent movement.
- 10.2 Ensure that nothing can impede the movement of the incubator on the cradle (such as a mains cable, tubing or having the incubator too close to a wall).
- 10.3 Altricial species such as parrots or birds of prey may benefit from additional manual turning through a full 180° once or twice a day.

11.0 Hatching

- 11.1 If hatching in the Octagon Pro-20, unplug the autoturn cradle and remove the incubator from the cradle. Place the incubator on the work surface in the upright position and remove the egg dividers two days before the hatch is due.
- 11.2 For maximum setting capacity, cleanliness, flexibility and performance a separate hatcher may be used. A second Brinsea Octagon 20, Octagon 10 or Hatchmaker incubators are recommended. Contact your dealer for details.
- 11.3 Eggs nearing hatch are slightly less sensitive to temperature variation and the hatching temperature can be reduced by up to 1°C (2°F) but this is not essential.
- 11.4 Hatching humidity levels need to be high (see section 6.0 above) but note that the VENTILATION CONTROL MUST BE AT LEAST 1/3RD OPEN DURING HATCHING.
- 11.5 When most eggs have hatched (12 to 48 hours) remove the hatchlings to a brooder. The Brinsea TLC-4 brooder or Octagon 20 Parrot Rearing Module are recommended for exotics and the Cosylamp for precocious species.
- 11.6 During hatching the high humidity levels will fall dramatically when the lid is lifted and will take some time to build up. Resist the temptation to open the incubator frequently – leave for at least 6 hours between inspections.

12.0 Cleaning Up

12.1 **IMPORTANT:**

DISCONNECT THE INCUBATOR AND BASE FROM THE MAINS POWER SUPPLY DURING CLEANING.

ENSURE THAT ALL ELECTRICAL PARTS ARE KEPT DRY.

NEVER WASH THE TRAYS, COVERS OR CABINET PARTS IN LIQUIDS OVER 120°F (50°C).
DO NOT USE A DISHWASHER TO CLEAN TRAYS, CABINET BASE OR LID.

- 12.2 Following each hatch in the Octagon Pro-20 remove and wash the egg tray, dividers and yellow base in Brinsea Incubation Disinfectant Concentrate (the foam parts of the dividers will need drying thoroughly before re-use. Wipe all internal surfaces with a soft cloth soaked in the sterilising solution. Periodically unscrew the four nuts retaining the fan cover, remove the cover and soak. Dust and fluff may be removed from the fan with a soft brush.
- 12.3 If a separate hatcher is used the procedure above should still be followed every two months.
- 12.4 The exterior of the incubator, Humidity Management Module and Autoturn cradle may be cleaned with a damp cloth. Avoid allowing any moisture to get inside mechanical housings.
- 12.5 Always clean the incubator before storage and ensure that the unit is totally dry inside and out.

13.0 Servicing

IMPORTANT: THE HEATER IS AT MAINS VOLTAGE. NEVER DRILL INTO OR PUNCTURE THE CLEAR LID OF THE INCUBATOR. RISK OF ELECTRIC SHOCK.

- 13.1 Under certain conditions it is possible that condensation may form between the inner and outer clear top mouldings. The presence of water between these layers does not affect the performance of your incubator and does not pose an electrical hazard because the element itself is sealed and the live parts are not exposed. To disperse condensation leave the incubator running without eggs or water in a warm room.
- 13.2 In case of failure first check that the mains power supply is working. If the problem persists contact your distributor or Brinsea Products Service Dept.
The functional parts of the Octagon Pro-20 are modular and parts are available and are readily exchanged by a suitably qualified person equipped with basic tools. Fitting instructions are supplied with replacement parts.
- 13.3 The digital temperature display is individually calibrated during manufacture but may be re-calibrated if required. To ensure optimal performance return the incubator to Brinsea Products Service dept. for re-calibration every two years. It is not recommended that this procedure is carried out by the user.

Humidity Management Module:

13.4 **Changing the pump tube**

The peristaltic pump will need to have its tube replaced about every 3 months. Cut a length of tube to about 135mm (5¼"). Remove the connectors by lifting them off the module and pull the old tube off the nipples. Replace with the new tube, avoiding twists. Use the diagram on the product label to thread the tube correctly over the pump head. The tension must be sufficient to ensure complete occlusion of the tube without

unnecessary flattening between the pump rollers. Adjust tube length as necessary. Ensure that the tube does not stick together if left for long periods by unhooking it during storage.

13.5 **Changing the evaporating pad**

Change the pad as necessary to maintain good evaporating efficiency. If chicks are to be hatched in the incubator, change the pad after each hatch to avoid bacterial contamination.

13.6 No lubrication or further servicing is required beyond the instructions above.

14.0 **Troubleshooting**

14.1 Poor hatching results are frustrating and can be caused by a large number of factors. The most common are given below.

14.2 Gather as much information from the hatching results as possible to enable the problem to be analysed in detail. Record dates that eggs are set, incubator settings, dates of hatches, weight losses and the number and condition of hatchlings. Candle or break open unhatched eggs to estimate the extent of embryo development. The Brinsea Cool-Lume or Egg-Lume candling lamps are available from your dealer.

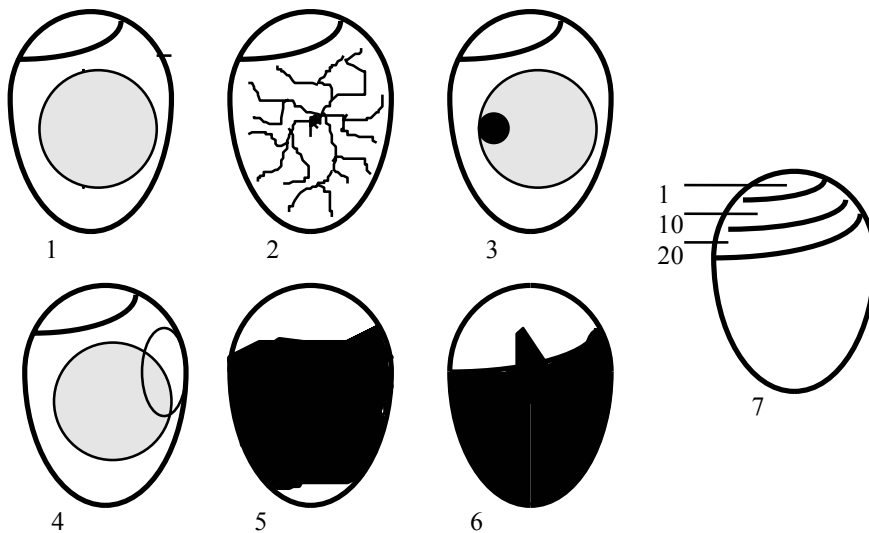

- 1) Clear when candled - probably infertile (or very early death) when candled at 1/3 of the incubation period
- 2) Fertile with red blood vessels - after 1/3 of the incubation period
- 3) Red or black staining - early death when candled after 1/3 of the incubation period
- 4) Embryos with red blood 'ring' - early death when candled after 1/3 of the incubation period
- 5) Dark outline with ill defined detail - late death (1/2 or 2/3 through incubation period)
- 6) Live embryo with bill in air sack - due to hatch in 24-48 hours
- 7) Normal development of the air pocket according to number of days

14.3 Some general guides:

Observation	Likely Cause(s)	Solution(s)
No chicks hatch	Infertility, infection, drastically incorrect incubation settings, parent ill health.	Check egg viability – are similar eggs hatching naturally. Disinfect the incubator. Check incubator settings and procedures – particularly temperature.
Chicks hatch earlier than expected, deformities.	Incubation temperature too high	Reduce incubation temperature slightly 0.5°C (1°F)
Chicks hatch later than expected	Incubation temperature too low	Increase incubation temperature slightly 0.5°C (1°F)
Hatch dates widely spread	Different rates of development due to different storage times, incubation temperature variation.	Limit egg storage times. Check for incubation temperature variation – sunlight, large room variation etc.
Late stage ‘death in shell’	Incorrect humidity, probably too high.	Try reducing average humidity levels (but see section 6 above)
Generally poor results	Incorrect incubation settings, poor parent bird health, inadequate egg turning,	Improve parent bird health, check all incubation settings, analyse egg weight loss to confirm humidity correct, check turning working correctly.

14.4 **Humidity Management Module**

The control module is calibrated from 0 to 100% RH and is theoretically capable of controlling throughout most of the range. However, the minimum and maximum levels of humidity achievable in an incubator depend upon several factors, particularly the fresh air ventilation rate. You may need to allow 24 hours for humidity to stabilise after making changes.

If you cannot get the level of RH you want, consider these notes:

14.5 **Humidity will not go low enough**

First increase the fresh air ventilation level - enlarge ventilation holes in the incubator cabinet. This will help to disperse the moisture given up by the eggs. There will still remain a lower limit determined by the moisture content of the ambient air, particularly in warm humid conditions. This can only be countered by dehumidification of the room air outside the incubator with a branded dehumidifier but is rarely a problem in practice.

14.6 **Humidity will not go high enough**

Restrict fresh air ventilation to the minimum safe level. Remember chicks need to breathe! Increase evaporating pad area. If the pad is too small, you may have a flood in your incubator.

Do not attempt to achieve higher than 80% RH.

Check that water is reaching the incubator when the pump runs – if not check the whole length of the tubing for kinks and check that the tubing around the pump has not become permanently flattened. If it has, replace the pump tube.

14.7 If further problems are experienced please contact your retailer or Brinsea Products at the address below.

15.0 Specification

OCTAGON Pro-20 Maximum Setting Capacities:

<u>Egg size</u>	<u>No. eggs</u>
Quail	42
Pheasant	28
Amazon/Macaw	26
Hen	18
Duck	14

Dimensions : Incubator & Autoturn Cradle 400mm x 250mm x 280mm high

Weight: Incubator & Autoturn Cradle 3.3Kg

Power Consumption: Octagon Pro-20 max. 50 Watts
Octagon Pro-20 typical average 25 Watts

Electrical Supply: 230v 50Hz

H22 Humidity Management Module:

Sensing method: Precision bulk polymer.
Sensor accuracy +/- 3%. Hysteresis 0% R.H.
Response time 2 minutes

Water Transfer: In-built peristaltic pump
Maximum water flow rate 0.5g/minute (H22)

Control setting and metering:
Indicated in % RH (linear)

Electrical supply: 220-240v 50Hz

Power consumption: 12 Watts Max.

Dimensions: 170mm x 200mm x 120mm (WxDxH)

Weight: 1kg

Brinsea Products Ltd, Station Road, Sandford, N. Somerset, BS25 5RA
Tel: (01934) 823039 Fax: (01934) 820250
e-mail: sales@brinsea.co.uk, website: www.Brinsea.co.uk